

Atomic layer epitaxy of rare earth oxide films on GaAs(111)A and their device properties

Yiqun Liu^{1*}, Min Xu²⁾, Jaeyeong Heo¹⁾, Peide D. Ye²⁾, and Roy G. Gordon^{1)**}

1) Department of Chemistry and Chemical Biology, Harvard University, Cambridge, Massachusetts, U.S.A.

2) School of Electrical and Computer Engineering, Purdue University, West Lafayette, Indiana, U.S.A.

Email: * yiqunliu@fas.harvard.edu, ** gordon@chemistry.harvard.edu

The aggressive scaling of MOSFETs has created interest in using high-mobility III-V channel materials to replace traditional strained Si. However, it has been challenging to form high- κ dielectrics that can passivate III-V surfaces with a low interface state density (D_{it}). We deposited LaLuO₃ high- κ dielectric layer by ALD on sulfur-passivated GaAs substrates. The precursors lanthanum tris(*N,N'*-diisopropylformamidate), and lutetium tris(*N,N'*-diethylformamidate) reacted with water vapor at 350 °C. The compositional ratio of La:Lu was about 1:1 by using one cycle of La₂O₃ followed by one cycle of Lu₂O₃ in one complete cycle of LaLuO₃. Both high-resolution XRD analysis and TEM showed that ALD LaLuO₃ formed epitaxially on GaAs(111)A substrates, as shown in Figures 1 and 2, respectively. The epitaxial layer exhibited a cubic structure with a lattice constant smaller than GaAs by 3.8%. The LaLuO₃ film had a high degree of crystalline perfection and was relaxed and not strained. Electrical characterizations showed the measured dielectric constant of around 30, which is close to its bulk crystalline value. The interface had a low interface state density (D_{it}) of $\sim 7 \times 10^{11} \text{ cm}^{-2} \text{ eV}^{-1}$. The amount of lattice mismatch can be engineered by choosing various rare-earth oxides. ALD La₂O₃ formed cube-on-cube epitaxy on GaAs(111)A with a lattice constant just +0.9% larger than that of the substrate. The mismatch can be reduced to zero by adding some Y₂O₃ to the La₂O₃, using yttrium tris(*N,N'*-diisopropylactamidate)/H₂O cycles. Perfect zero-mismatched epitaxy was achieved on GaAs(111)A by depositing La_{1.7}Y_{0.3}O₃, as shown in Figure 3. The effects of mismatch on the electrical properties of epi-LaYO₃ on GaAs(111)A were studied. These results suggest that atomic layer epitaxy of rare-earth oxides/GaAs(111)A is a promising structure for future generations of high-power/high-frequency analog devices or high-speed logic devices.

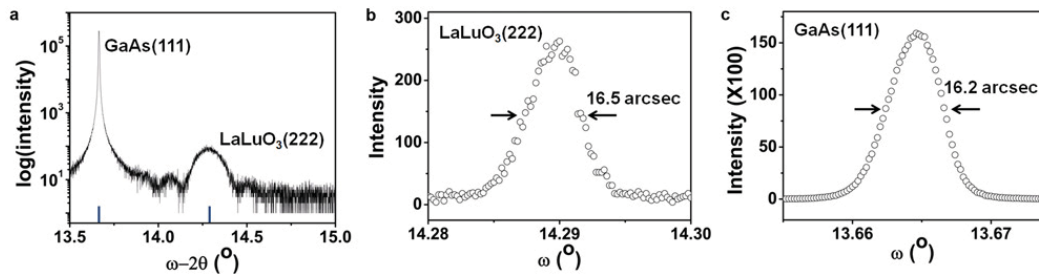

Figure 1 (a) High-resolution X-ray omega-two theta scan for LaLuO₃ film on GaAs(111)A. (b) and (c) The rocking curves of the LaLuO₃ (222) peak and the GaAs(111) peak, respectively.

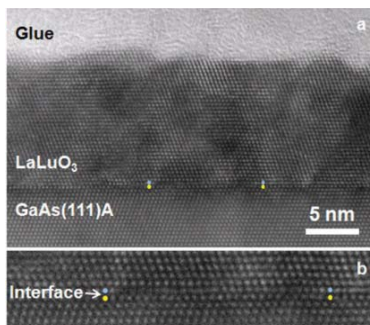

Figure 2 (a) Cross-sectional TEM of LaLuO₃/GaAs(111)A heterostructure. (b) A magnified image of the interface.

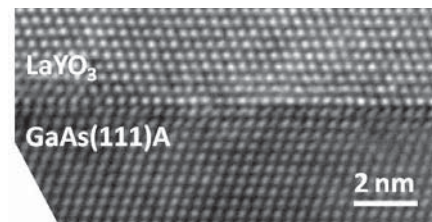

Figure 3. Cross-sectional TEM of La_{1.7}Y_{0.3}O₃/GaAs(111)A. The mismatch is zero for this composition with 15% Y₂O₃



Atomic Layer Epitaxy of Rare Earth Oxide Films on GaAs and Device Properties

2011 ALD Meeting

Yiqun Liu¹⁾, Min Xu²⁾, Jaeyeong Heo¹⁾, Peide D. Ye²⁾, and Roy G. Gordon¹⁾

1) Department of Chemistry and Chemical Biology, Harvard University

2) School of Electrical and Computer Engineering, Purdue University

Motivation

- **High- κ and high mobility for future scaling**
- **GaAs: high electron mobility**
- **Issue: small I_{DS} in GaAs NMOSFET ← Fermi-level pinning**
- **Fermi-level unpinning: GaAs(111)A with ALD Al_2O_3 ***
(Prof. Ye's group at Purdue)

* "Metal-oxide-semiconductor field-effect transistors on GaAs (111)A surface with atomic-layer-deposited Al_2O_3 as gate dielectrics." M. Xu, Y. Q. Wu, O. Koybasi, T. Shen, and P. D. Ye, *Appl. Phys. Lett.* 94, 212104 (2009).

High-k on GaAs for EOT scaling

| on GaAs | k | Band gap (eV) | ΔE_c (eV) | ΔE_v (eV) |
|-----------------------------|------------------|---------------|-------------------|-------------------|
| Al_2O_3 | 8 | 6.5 | 1.8 | 3.4 |
| HfO_2 | 12 | 6.2 | 1.8 | 3 |
| $LaAlO_3$ | 15 | 5.8 | 1.6 | 2.8 |
| $GdScO_3$ | 22 | 5.7 | 2 | 2.3 |
| $LaScO_3$ | 23 | 5.6 | 2 | 2.3 |
| $LaLuO_3$ | 32 (bulk) | 5.6 | 2.1 | 2.2 |

“Band offsets of high K gate oxides on III-V semiconductors” J. Robertson and B. Falabretti, *J. Appl. Phys.* 100, 014111(2006)

ALD process for LaLuO₃ films

- **Metal amidinate precursor for ALD La₂O₃:**

- Lanthanum tris(*N,N'*-diisopropylformamidinate) or La(*i*Pr₂-fAmd)₃
- white solid
- most volatile La compound known, 60 mTorr at 100 °C
- high reactivity to H₂O, O₂ and NH₃

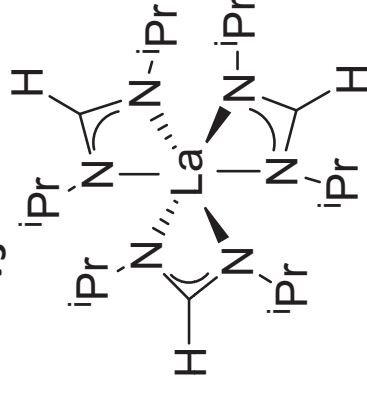

- **Metal amidinate precursor for ALD Lu₂O₃:**

- Lutetium tris(*N,N'*-diethylformamidinate) or Lu(Et₂-fAmd)₃
- more volatile than La(*i*pr₂-fAmd)₃

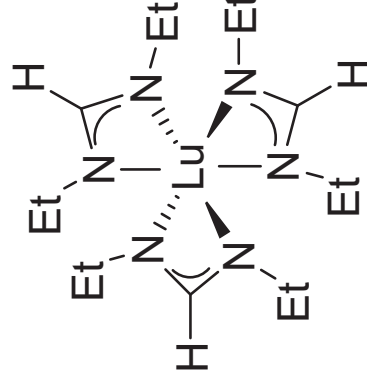

ALD process for LaLuO₃ films

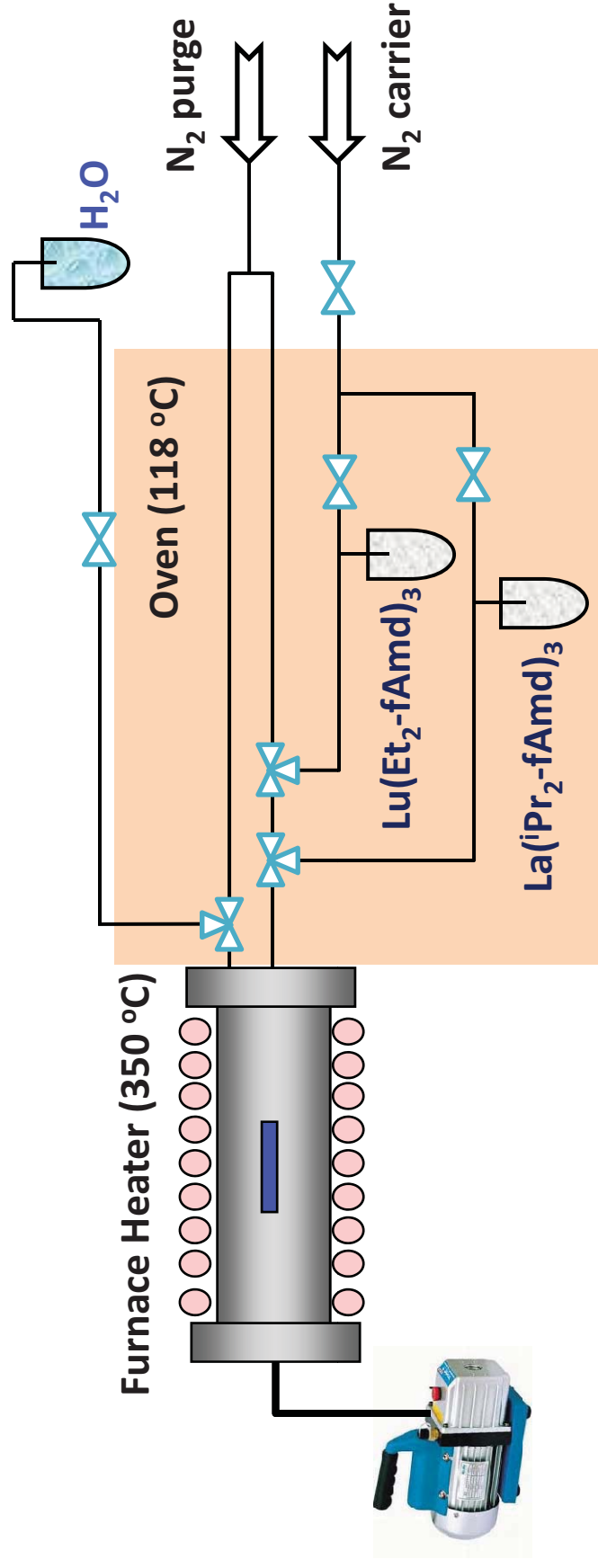

ALD process condition for LaLuO₃

| MO precursors | Oxidant | Bubbler temp. | Deposition temp. | La ₂ O ₃ : Lu ₂ O ₃ | Exposure |
|--|---------------------|---------------|------------------|---|--|
| La(ⁱ Pr ₂ -fAmd) ₃ Lu(Et ₂ -fAmd) ₃ | DI H ₂ O | 118 °C | 300-350 °C | 1:1 | 0.003 Torr s for metal precursor 0.06 Torr s for H ₂ O |

Properties of ALD LaLuO_3

- **Composition (RBS)**
 - La:Lu=1:0.9
 - 80% of bulk density
 - C and N not detectable
- **Amorphous on Si with abrupt interface ($\kappa \sim 26$)**
- **Highly conformal (90% step coverage)**

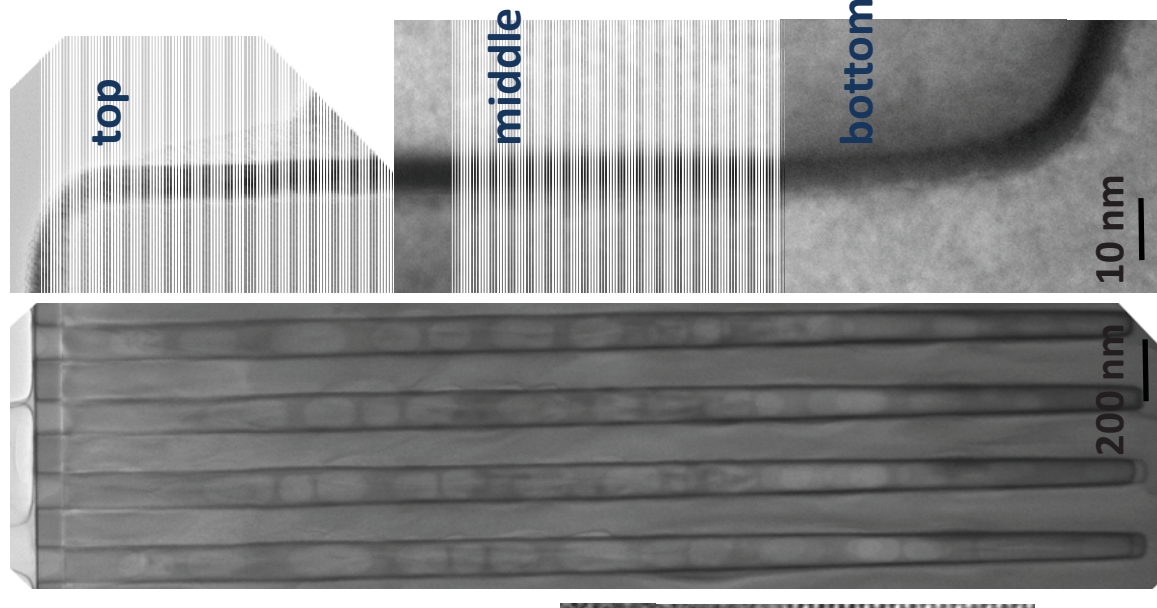
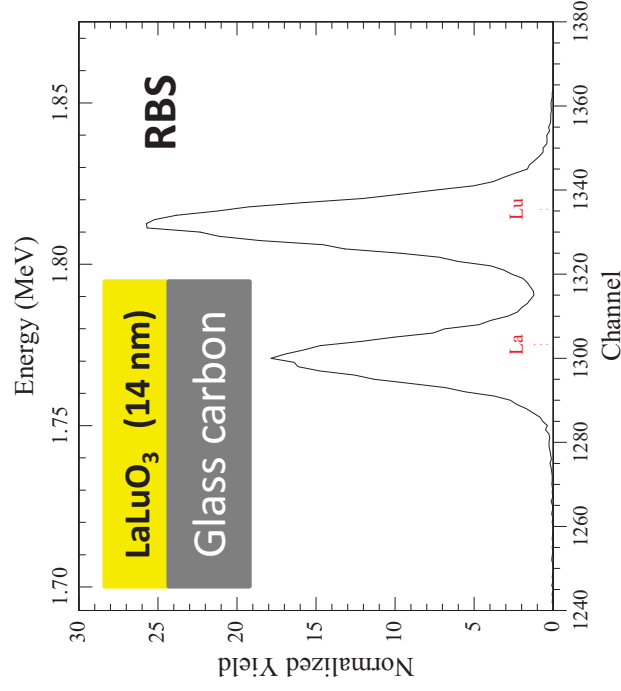

TEM, aspect ratio: 65:1*

*H. Wang, J.-J. Wang, R. Gordon, J.-S. M. Lehn, H. Li, D. Hong, and D. V. Shenai, *Electrochem. Solid-State Lett.* 12, G13 (2009).

Properties of ALD LaLuO_3 on $\text{GaAs}(111)\text{A}$

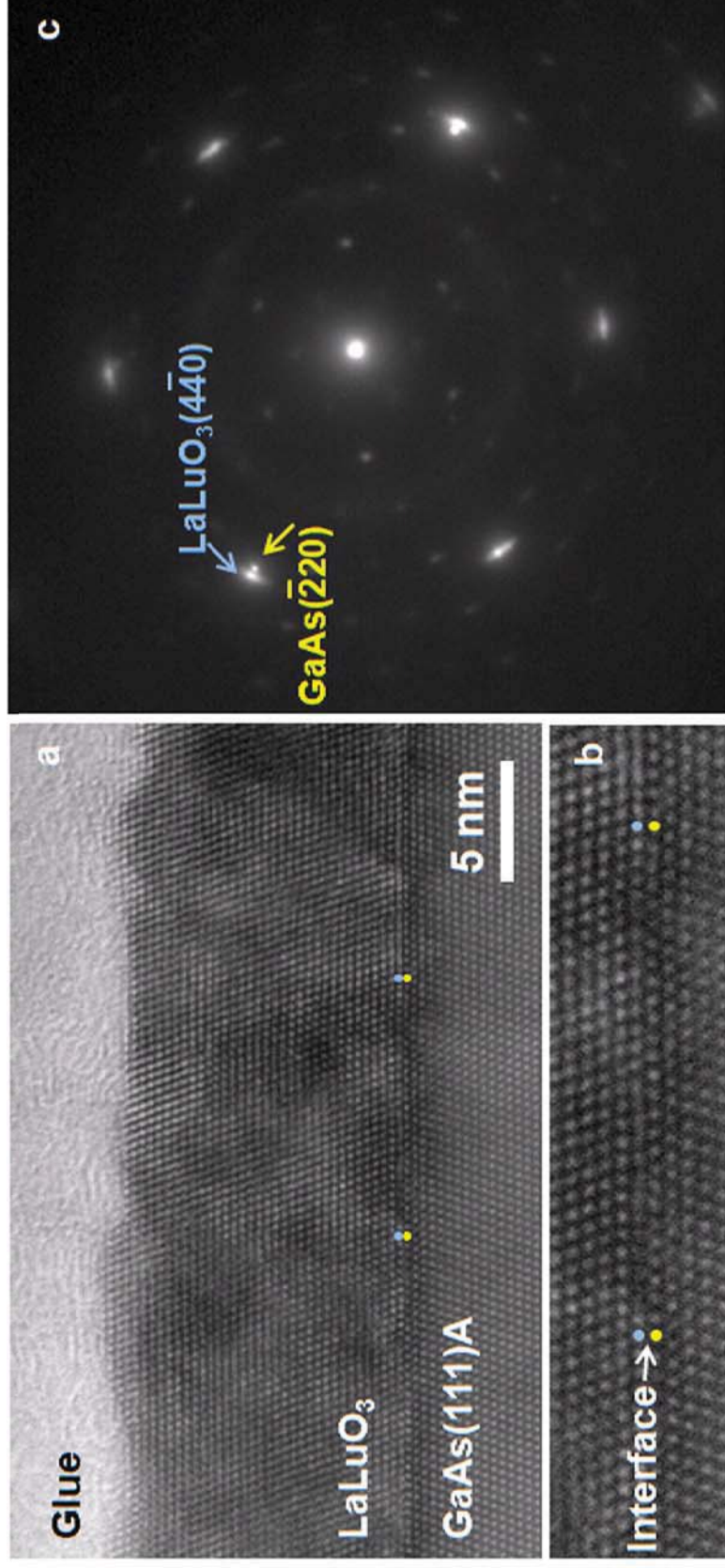

- Lattice mismatch $\sim 4\%^*$
- Relaxed
- Epitaxy: cubic, **not** orthorhombic!

* defined as $(a_{\text{oxide}} - 2a)/2a$

“Hetero-epitaxy of single-crystal LaLuO_3 on $\text{GaAs}(111)\text{A}$ by atomic layer deposition” Yiqun Liu, Min Xu, Jaeyeong Heo, Peide D. Ye, and Roy G. Gordon, *App. Phys. Lett.* 97, 162910 (2010).

Quality of ALD epi-LaLuO₃ on GaAs(111)A

- High-resolution XRD measurements

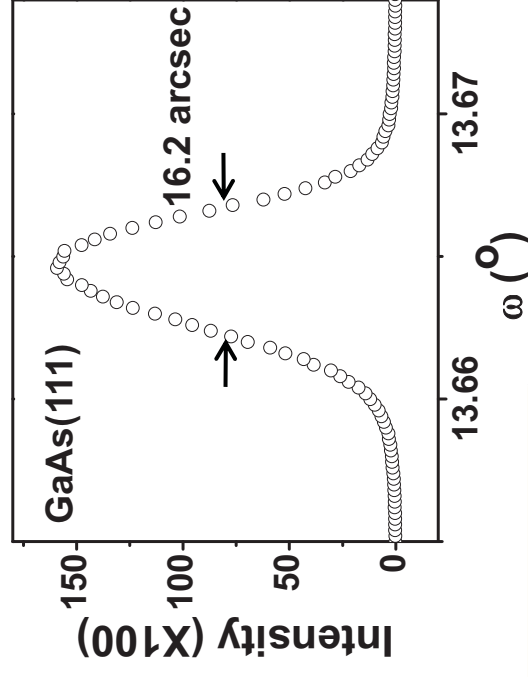
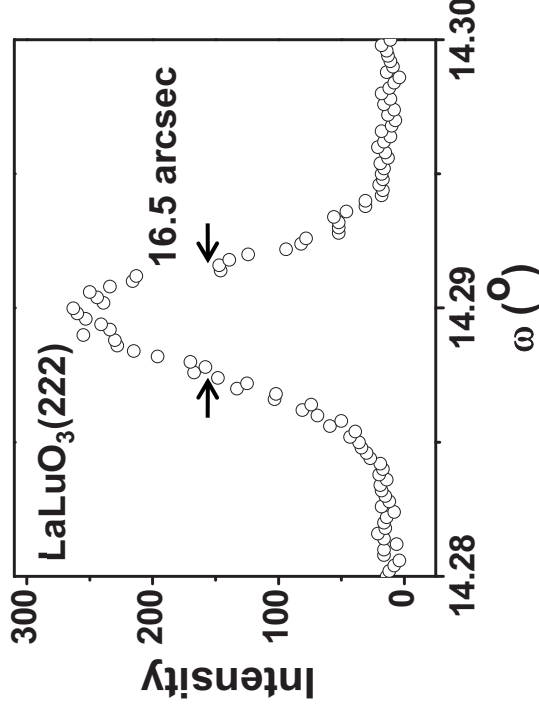
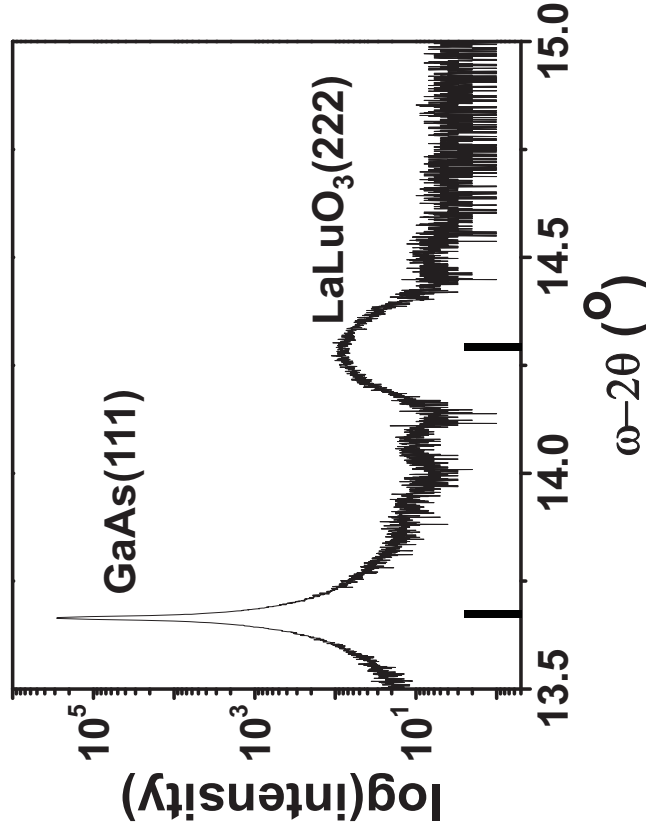

- Mismatch ~-3.8%
- Crystalline uniformity
- FWHM of the film peak

The quality of epitaxy is comparable to GaAs

Substrate-dependent crystal structures

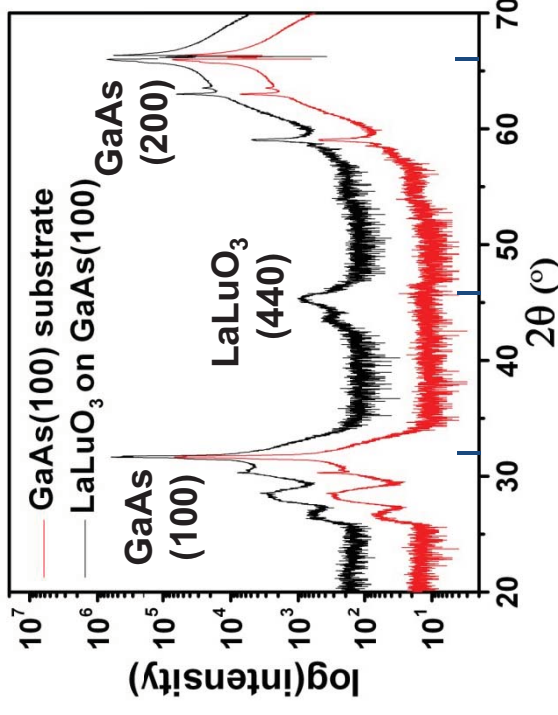
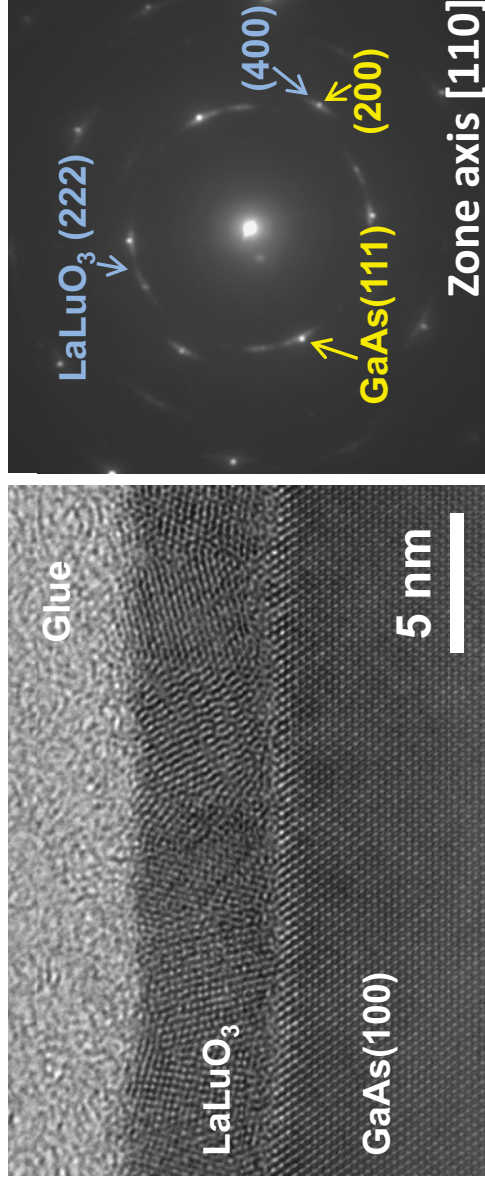

- Cubic polycrystalline with (110) preferential orientation on GaAs(100)

Substrate-dependent crystal structures

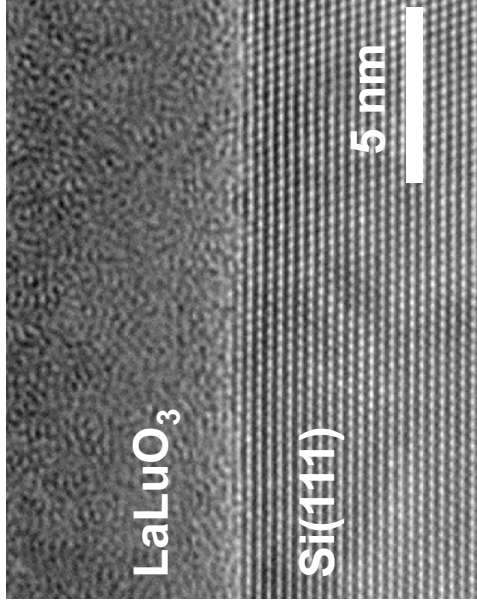
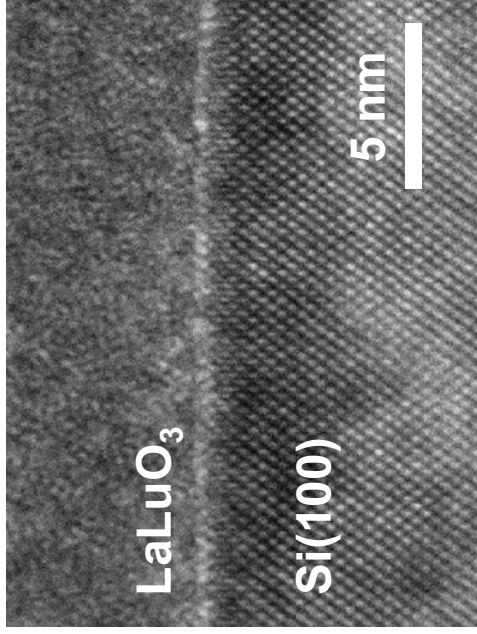

- **Amorphous on Si (0.18% mismatch)**
- Silicate IL formation → Disturb ordering of substrate.

Epi-LaLuO₃/GaAs(111)A: no amorphous IL desirable for EOT scaling

¹ J. Kwon, M. Dai, M. D. Halls, E. Langereis, Y. J. Chabal, and R. G. Gordon, *J. Phys. Chem. C* 113, 654 (2009).

² Yiqun Liu, Shaoping Shen, Leonard J. Brillson, and Roy G. Gordon, *App. Phys. Lett.* 98, 122907 (2011).

Electrical properties

- Epi-LaLuO₃ v.s. a-Al₂O₃ on GaAs(111)A

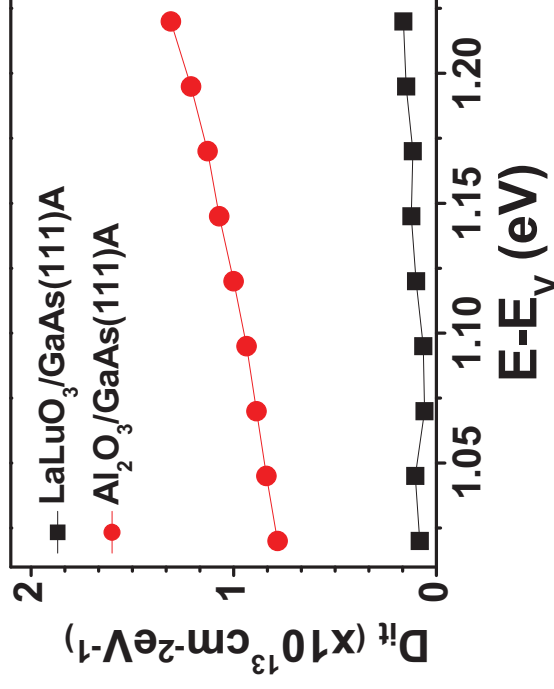
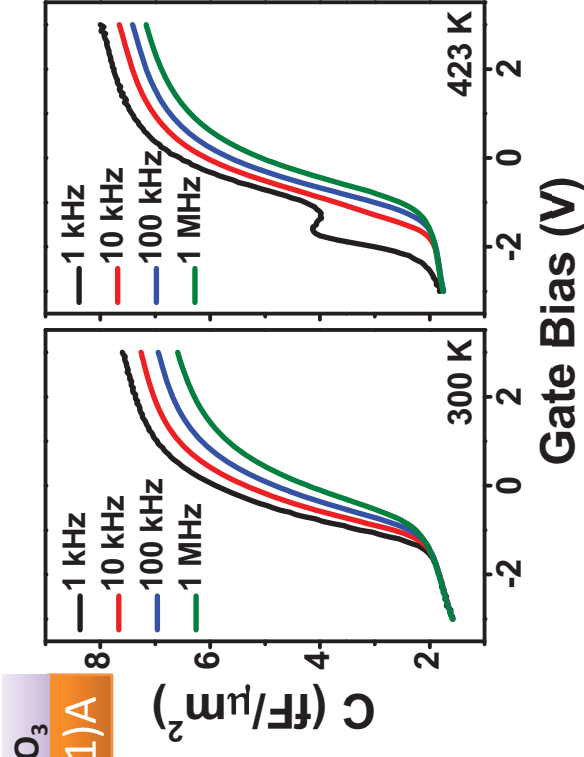
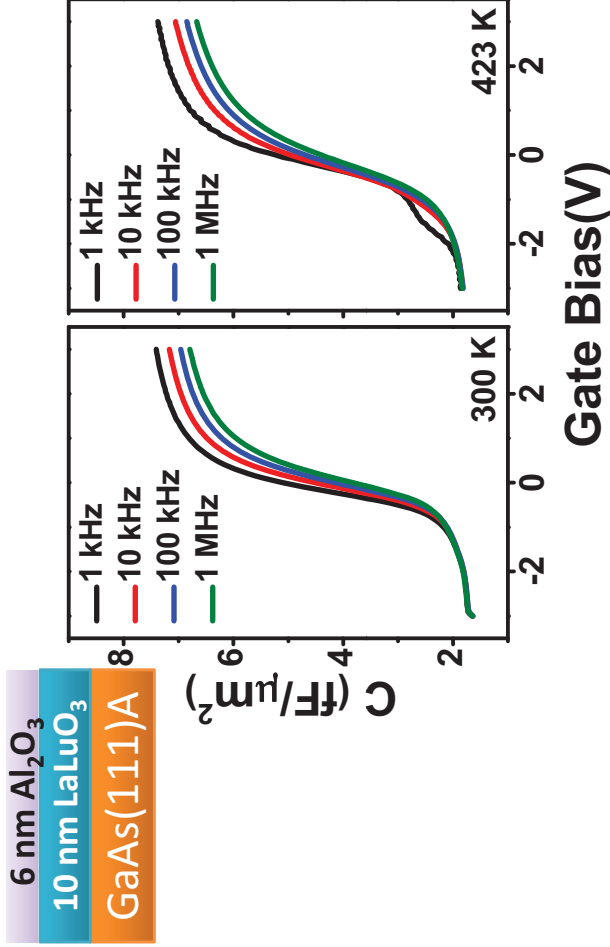

✓ Dielectric constant is ~ 30

✓ Smaller V_{FB} & frequency dispersions

✓ Interface state density (D_{it}) $\sim 7 \times 10^{11} \text{ cm}^{-2} \text{ eV}^{-1}$

LaLuO₃/GaAs(111)A : **better interface**

Lattice mismatch engineering

- ALD La_2O_3 on GaAs(111)A
 - nearly zero lattice mismatch (+0.8%)
 - cubic phase (*not tetragonal*), $\kappa \sim 23$

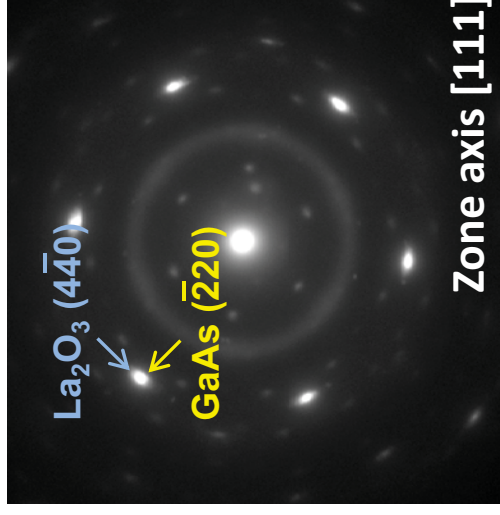
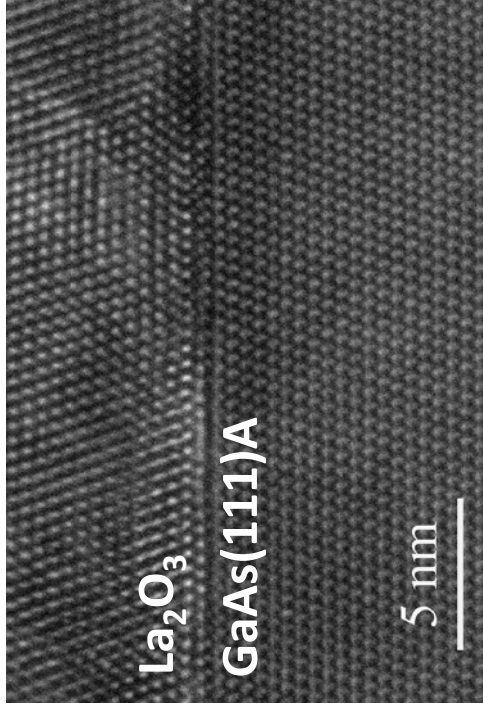

Lattice mismatch engineering

$$a_{\text{Y}_2\text{O}_3} = 1.061 \text{ nm}$$

$$a_{\text{La}_2\text{O}_3} = 1.141 \text{ nm}$$

$$2 * a_{\text{GaAs}} = 1.130 \text{ nm}$$

| |
|-----------|
| Sc |
| Y |
| La |
| Ce |
| Pr |
| Nd |
| Pm |
| Sm |
| Eu |
| Gd |
| Tb |
| Dy |
| Ho |
| Er |
| Tm |
| Yb |
| Lu |

Adjust lattice parameters to get perfect lattice match

- **Metal amidinate precursor for ALD Y_2O_3**

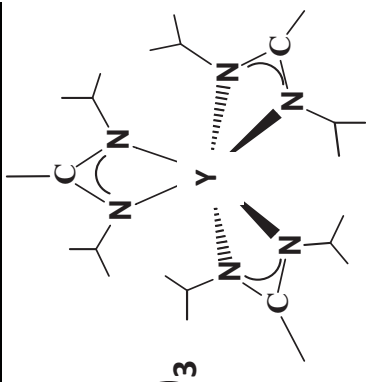

- Yttrium tris(*N,N'*-diisopropylacetamidinate) or $\text{Y}(\text{iPr}_2\text{-amd})_3$

- White solid, less volatile

- **ALD LaYO_3 @300 °C**

| Subcycle ratio | Composition | Lattice mismatch |
|--|---|------------------|
| $\text{La}_2\text{O}_3 : \text{Y}_2\text{O}_3$ | La_2O_3 | +0.8% |
| 3:1 | $\text{La}_{1.7}\text{Y}_{0.3}\text{O}_3$ | 0 |
| 1:2 | $\text{La}_1\text{Y}_1\text{O}_3$ | -2.5% |
| 0:1 | Y_2O_3 | -6% |

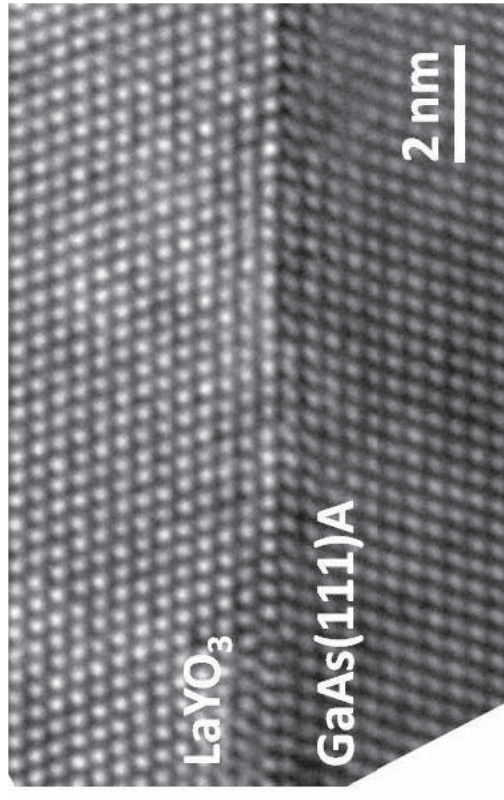

Summary

- **Substrate-dependent structures of ALD LaLuO₃**
 - Epitaxy on GaAs(111)A
 - Poly. on GaAs(100)
 - Amorph. on Si
- **Promising electrical properties of epi-LaLuO₃/GaAs(111)A**
 - High k and low D_{it}
 - Fermi-level is unpinned
- **Lattice mismatch engineering**
 - La_{1.7}Y_{0.3}O₃ on GaAs(111)A: perfect lattice match

Acknowledgements

- Prof. Roy Gordon
and all group members
- Prof. Peide D. Ye and Min Xu
- Dr. Jun-Jieh Wang prepared Lu precursor
- Dow Chemical provides La and Y precursor
- Center for Nanoscale Systems (CNS) at Harvard



Electrical properties

- Effect of sulfur passivation



Sulfur passivation

Without passivation

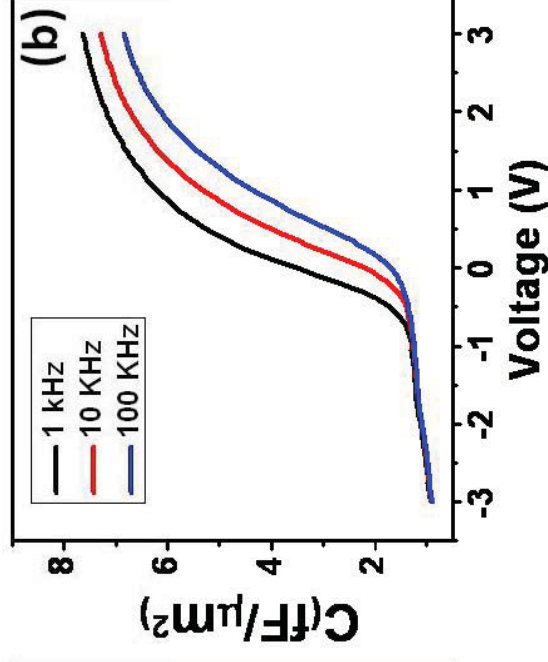
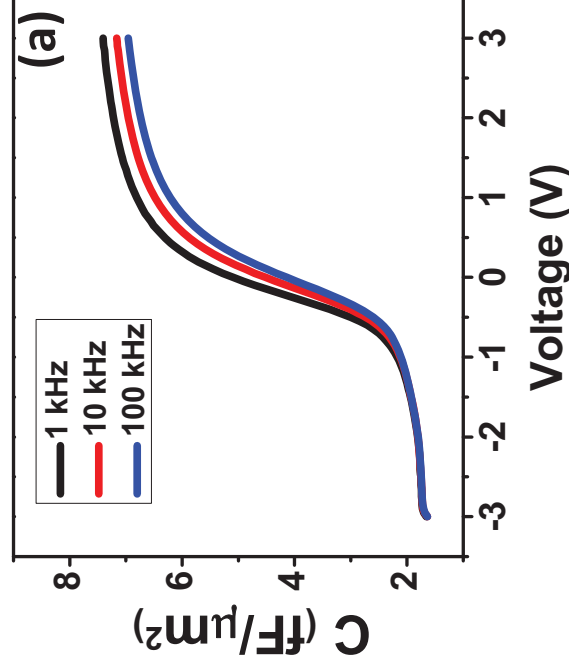

All devices: RTA in N_2 at 700 °C before Ni electrodes were patterned on the devices.

Electrical properties

- GaAs(111)A v.s. GaAs(100)

6 nm Al₂O₃
10 nm LaLuO₃
GaAs(111)A

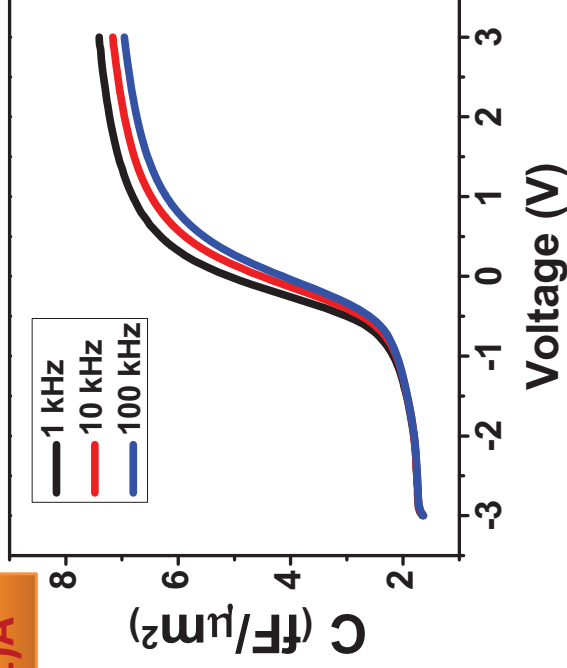

6 nm Al₂O₃
10 nm LaLuO₃
GaAs(100)

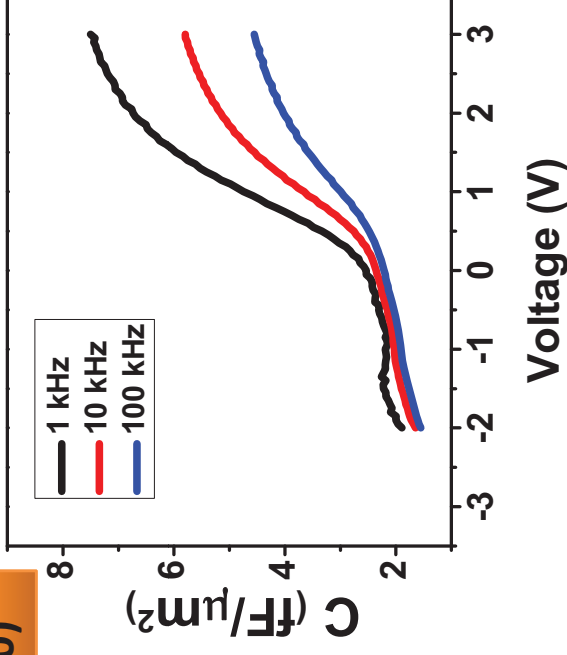

Fermi-level is partially pinned and D_{it} is higher on GaAs(100).

Fermi-level is unpinned on GaAs(111)A.